

# BG Series

Close-coupled self-priming centrifugal pumps with built-in ejector system, designed to remain primed even in the presence of water-dissolved gases. The extensive use of pressed stainless steel ensures a high-performance, durable and lightweight pump.

Available in the "Garden" version with handle and terminal box with built-in switch.

## Specifications

Delivery: up to 4.2 m<sup>3</sup>/h  
Head: up to 53 m  
Power supply: three-phase and single-phase 50 and 60 Hz  
Power: 0.37 kW to 1.1 kW  
Maximum operating pressure: 8 bar  
Maximum total lift: 8 m  
Maximum ambient temperature: 40°C  
Temperature of pumped liquid: -10°C to +40°C  
Insulation class: F  
Protection: IP55

## Materials

Pump body: Stainless steel  
Impeller: Stainless steel  
Diffuser: Technopolymer  
Ejector: Technopolymer  
Seal housing: Stainless steel  
Mechanical seal: Ceramic/Carbon/EPDM  
Fill and drain plugs: Nickel-plated brass  
Elastomers: EPDM

## Applications

Water distribution

Pressure boosting

Irrigation

Washing

Rain water collection

Swimming pools

Fountains



For a complete list of technical information, consult [www.lowara.com](http://www.lowara.com)

# BG SERIES

## Operating characteristics at 50 Hz

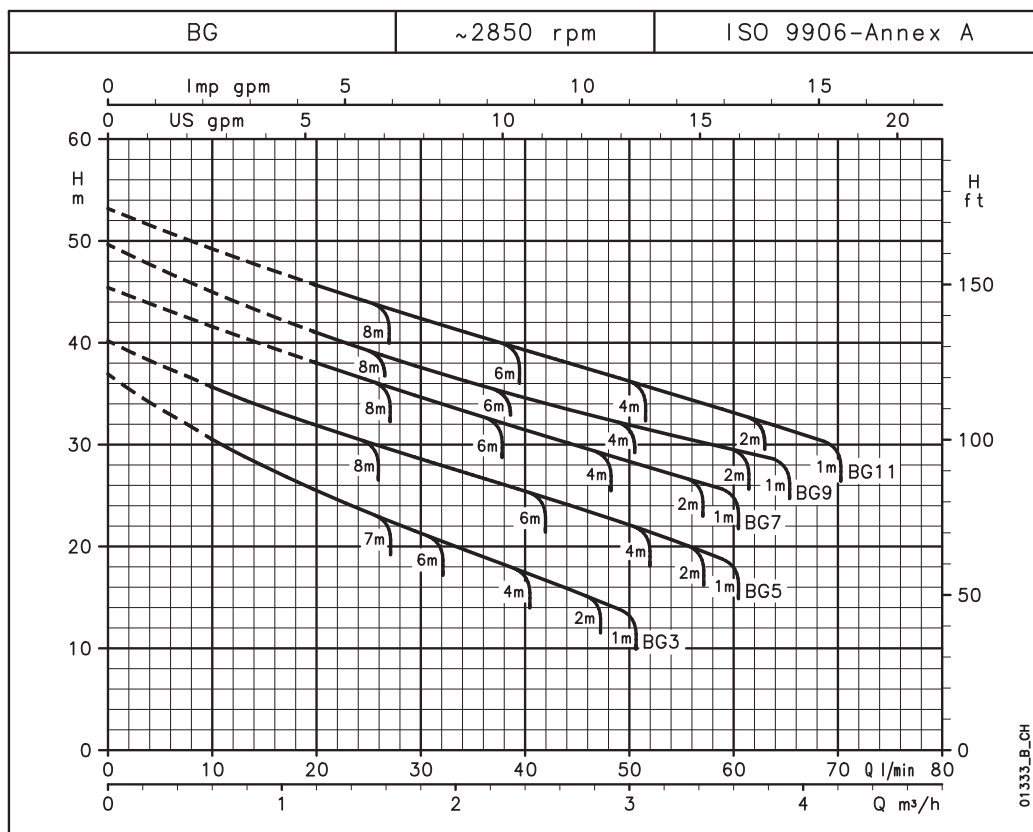

### Hydraulic performance table

PUMP TYPE	RATED POWER		Q = DELIVERY								
	kW	HP	l/min	10	20	30	40	50	60	65	70
			m <sup>3</sup> /h	0,6	1,2	1,8	2,4	3	3,6	3,9	4,2
			H = TOTAL HEAD IN COLUMN OF WATER (METRES)								
BG(M)3	0,37	0,5	36,9	30,6	25,6	21,5	17,7	13,8			
BG(M)5	0,55	0,75	40,2	35,7	32,0	28,8	25,7	22,4	18,8		
BG(M)7	0,75	1	45,4		38,1	34,8	31,7	28,6	25,6		
BG(M)9	0,9	1,2	49,6		41,1	37,7	34,8	32,2	29,8	28,6	
BG(M)11	1,1	1,5	53,2		45,8	42,5	39,5	36,5	33,5	31,9	30,3

Maximum delivery depends on geodetic suction lift with clean 8 m pipe and 1 1/4" foot valve.

bg-2p50\_a\_th

These performances are valid for liquids with density  $\rho = 1.0 \text{ kg/dm}^3$  and kinematic viscosity  $\nu = 1 \text{ mm}^2/\text{s}$ .

### Electrical data

PUMP TYPE	MOTOR TYPE	INPUT			PUMP TYPE	MOTOR TYPE	INPUT		
		POWER*	CURRENT*	CAPACITOR			POWER*	CURRENT*	CURRENT*
1 ~		kW	A	$\mu\text{F} / 450 \text{ V}$	3 ~		kW	A	A
BGM3	SM63BG/1045	0,67	2,96	14	BG3	SM63BG/304	0,68	2,56	1,48
BGM5	SM71BG/1055	0,91	4,33	16	BG5	SM71BG/305	0,81	2,74	1,58
BGM7	SM71BG/1075	1,11	5,00	20	BG7	SM80BG/307HE	1,07	3,32	1,92
BGM9	SM71BG/1095	1,24	5,54	25	BG9	SM80BG/311HE	1,15	3,65	2,11
BGM11	SM80BG/1115	1,43	6,47	30	BG11	SM80BG/311HE	1,34	4,12	2,38

\*Maximum value in specified range.

bg-2p50-en\_b\_te

# BG SERIES

## Dimensions and weights

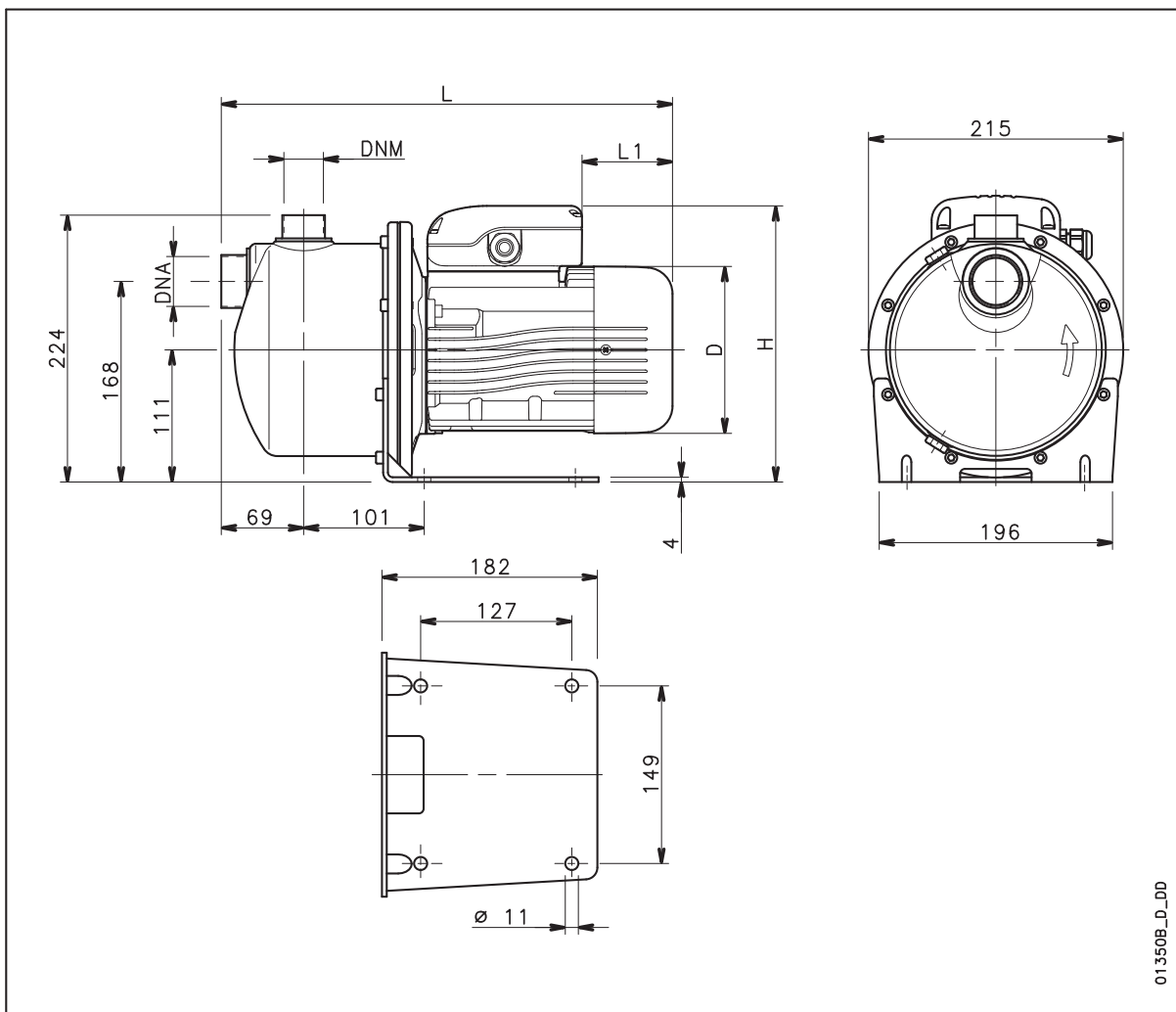

PUMP TYPE	DIMENSIONS (mm)				DNA	DNM	WEIGHT kg
	D	L	L1	H			
BGM3	120	366	62	222	Rp 1¼	Rp 1	10
BGM5	140	380	76	232	Rp 1¼	Rp 1	12
BGM7	140	380	76	232	Rp 1¼	Rp 1	13
BGM9	140	380	31	241	Rp 1¼	Rp 1	13
BGM11	156	425	69	248	Rp 1¼	Rp 1	16
BG3	120	366	62	222	Rp 1¼	Rp 1	10
BG5	140	380	76	232	Rp 1¼	Rp 1	12
BG7	155	425	114	240	Rp 1¼	Rp 1	17
BG9	155	425	114	240	Rp 1¼	Rp 1	19
BG11	155	425	114	240	Rp 1¼	Rp 1	19

bg-2p50-en\_c\_td